

PTB20-C

PTB20-C is the ideal choice for material transportation in medium or long distance,(optional foldable platform),suitable for most applications.
The high power vertical AC drive system ensures the high performance of the truck.



ADVANTAGES

- Robust and ergonomic design.
- AC drive system provides sufficient power.
- Steel battery cover and drive frame housing.
- Suitable for indoor heavy-duty applications in a long work cycle.
- American Curtis controller.
- 1.3KW high power vertical drive.

Noblelift Headquarters

Add:#528 Changzhou Road, Taihu
Sub-district, Changxing, 313100, China
TEL:+86 572 6210311/6120989
FAX:+86 572 6129336
WEB:www.noblelift.com
Email: info@noblelift.com



Official website



Our Wechat

Noblelift North America Corp.

Add:2461 S Wolf Road, Des Plaines, IL 60018
Tel:847-595-7100
Fax:847-595-7200
Email:sales@nobleliftna.com
Http: www.nobleliftna.com

Noblelift Europe GmbH

Add:Borsigstrasse 9d-93092 Barbing
Germany
TEL:+49 9401 607930
FAX:+49 9401 6079329
WEB:www.noblelifteurop.com
Email: mail@noblelifteurop.com

Noblelift Russia

ООО "Ноблелифт Рус"
194292, Санкт-Петербург
Домостроительная ул. 4А офис 301
Бизнес-центр "Парнас"
тел.: +7 (800) 700-28-97
Email: sales@noblelift.com.ru

NOBLELIFT

Material Handling

We promise, We deliver



PTB20-C Electric pallet truck

Ideal choice for most material handling applications



Rated Capacity
2000Kg

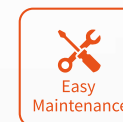

Easy
Maintenance



High
Performance



High Capacity
Battery



Robust and
Reliable Design

NEW *Noblelift Products*
ARRIVAL

NOBLELIFT INTELLIGENT EQUIPMENT CO., LTD

www.noblelift.com

Ergonomic designed Intelligent tiller head

Comfortable operation, optimize operator's comfort. All the switch buttons are integrated in the humanized touch position for easy operation. (Integrated pin code, hour meter, battery discharge indicator, fault code display, turtle speed)



High power vertical drive

The high power vertical AC drive system ensures the high performance of the truck. High capacity, Small turning radius, Excellent heat dissipation, Long service life and easy maintenance.

Vertical drive

1.3KW high power vertical drive, with the rotating support can be equipped with AC or DC motors, is suitable for heavy-duty applications in long work cycle.

Mature design



Easy pallet entry

Additional entry rollers ensure easy pallet entry and prevent possible damages.



Robust design

Strong metal battery cover and drive frame housing. The strong battery cover made out of steel helps to provide a high level of strength for this part.

Controller

American Curtis controller, which provides extremely reliable and flexible solutions with high performance level of the control system.

Other optional



Optional ergonomic tiller head

Ergonomic handle, easy to use on both sides. The turtle speed switch ensures safer operation in narrow spaces.



Optional control element

Key switch, emergency stop switch and electricity meter.



Foldable platform

Optional foldable platform and side guard rail. The ergonomically designed foldable platform in combination with its sideways protective arms makes operations faster and safer.



Optional American parts

Optional typical American fork frame with short fork tip.

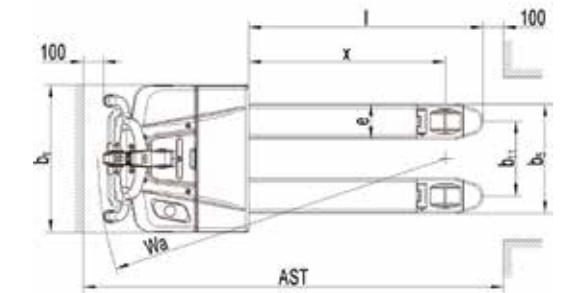
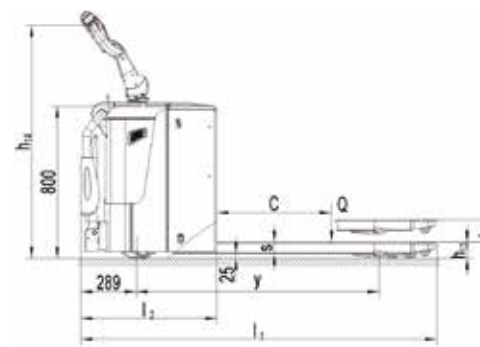

Type sheet for industrial truck acc. to VDI2198

Distinguishing mark

1.2	Manufacturer's type designation		PTB20-C
1.3	Drive		Battery
1.4	Operator type		Foldable platform
1.5	Load capacity/Rated load	Q (t)	2.0
1.6	Load centre distance	c (mm)	600
1.8	Load distance,centre of drive axle to fork	x (mm)	965
1.9	Wheelbase	y (mm)	1388

Weight

2.1	Service weight	kg	634 (With Foldable platform and guard rail)
2.2	Axle loading, laden front/rear	kg	960 / 1674
2.3	Axle loading,unladen front/rear	kg	514 / 120

Tires,chassis

3.1	Tires		Polyurethane(PU)
3.2	Tire size,front	Øxw (mm)	Ø 230×75
3.3	Tire size,rear	Øxw (mm)	Ø 84×84
3.4	Additional wheels(dimensions)	Øxw (mm)	Ø 100×40
3.5	Wheels,number front/rear(x=driven wheels)		1x2/2/4
3.6	Tread,front	b10 (mm)	500
3.7	Tread,rear	b11 (mm)	367

Dimensions

4.4	Lift	h3 (mm)	120
4.9	Height of tiller in drive position min./max.	h14 (mm)	946 / 1338
4.15	Height, lowered	h13 (mm)	85
4.19	Overall length	l1 (mm)	1762
4.20	Length to face of forks	l2 (mm)	612
4.21	Overall width	b1 (mm)	729
4.22	Fork dimensions	s/e/l (mm)	60 / 173 / 1150
4.25	Width across forks	b5 (mm)	540
4.32	Ground clearance, centre of wheelbase	m2 (mm)	25
4.34	Aisle width for pallets 800 x1200 lengthways	Ast (mm)	2250
4.35	Turning radius	Wa (mm)	1585

Performance data

5.1	Travel speed,laden unladen	km/h	6.0 / 6.0
5.2	Lift speed,laden/unladen	m/s	0.027 / 0.035
5.3	Lowering speed,laden/unladen	m/s	0.042 / 0.027
5.8	Max. gradeability, laden/unladen	%	6 / 10
5.10	Service brake		Eletromagnetic

Electric-engine

6.1	Drive motor rating S2 60min	kW	1.3
6.2	Lift motor rating at S3 10%	kW	0.8
6.3	Battery acc. to DIN 43531/35/36A,B,C,norm		B,2Pzb
6.4	Battery voltage,nominal capacity K5	V / Ah	24 / 180
6.5	Battery Weight(+/-5%)	kg	215
6.6	Energy consumption acc. to VDI cycle	kWh/h	0.75

Additional data

8.1	Type of drive control		AC speed Control
8.4	Sound level at driver's ear acc. to EN 12053	dB(A)	<70